

1064nm Nd:YAG q-switched picosecond laser MD Microchip laser system



DESCRIPTION

1064nm laser is one of the most common laser among ULaser's products of solid state laser. Unlike other lasers, 1064nm laser beam is directly emitted from the Nd:YAG crystal. Q-switched crystal helps our laser to emit picosecond output light beam. Either the one with single longitudinal mode or the one with fundamental mode can be chosen in ULaser.

ULaser provides absolute high quality 1064 nm laser. Our 1064nm laser contains high average power, up to 100mW. And it has high pulse repetition frequency, up to 50kHz. At the same time, our 1064nm laser has smaller size and lower power consumption by microchip laser technology.

Our 1064nm laser can be used in most military, civil and scientific research fields. In industry, it can be used in micromachining. In cosmetology, it can be used in picosecond laser tattoo removal machine. Besides, it can also be used in laser ultrasound, laser induced breakdown spectroscopy, etc.

FEATURES

- Pulse width up to 550ps
- Pulse energy up to 120μJ
- High polarization direction stability
- Maximum repetition rate up to 10kHz
- Beam mode is TEM₀₀
- Fully sealed design, high reliability

APPLICATIONS

- Seed source
- Micromachining
- Fluorescence lifetime measurement
- Laser-induced fluorescence
- Laser ionization mass spectrometry
- Non-linear optical measurement

OUTLINE SIZE(mm)

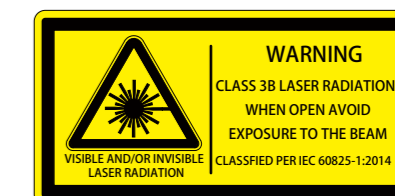
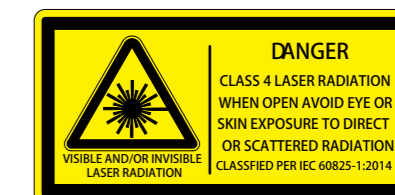
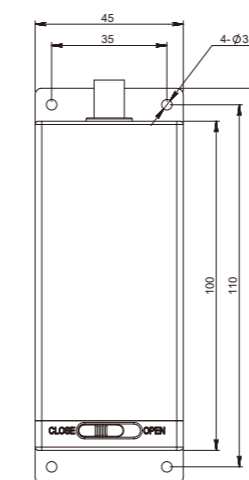
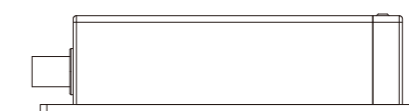
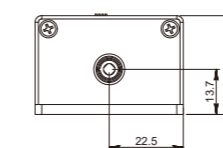
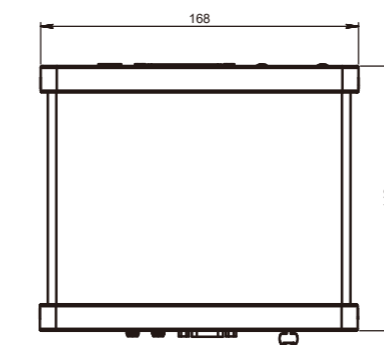
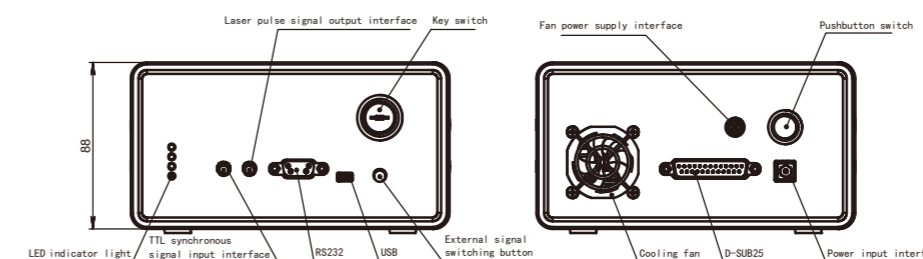

PARAMETERS

Model	UL1064-0.01kHz-300μJ-MD004	UL1064-0.01kHz-300μJ-MD005	UL1064-0.01kHz-300μJ-MD006	UL1064-0.1kHz-100μJ-MD007	
Optical parameter	Wavelength (nm)	1064	1064	1064	
	Repetition frequency (kHz)	0.01	0.01	0.01	
	Average power (mW)	3	3	3/3	10
	Output energy (μJ)	300	300	300/300	100
	Pulse width (ps)	350	350	500/2000	350
	Power stability (8h)	±3%	±3%	±3%	±3%
	Beam mode	TEM ₀₀	TEM ₀₀	TEM ₀₀	TEM ₀₀
	Full-angle divergence angle Typ. (Mrad) level@1/e ²	12	12	6-7	12
	Full-angle divergence angle Typ. (Mrad)Vertical@1/e ²	12	12	6-7	12
Polarization characteristics	P-polarization, > 100:1	P-polarization, > 100:1	500ps P-polarization, >100:1 2ns S-polarization, >100:1	> 100:1	
System parameters	System power consumption (W)	≤10	≤10	≤10	≤25
	Power input	12V 5A	12V 5A	12V 5A	100-240 VAC,50/60Hz
	Control interface	SMA	SMA	SMA	RS232、USB
	Power supply size (W × H × L, mm)	68×35×120	68×35×120	68×35×120	168×88×140
	Laser head size (W × H × L, mm)	45×30×120	45×30×120	80×36×124	45×30×120
	Working temperature (°C)	15-35	15-35	15-35	15-35
	Storage temperature (°C)	0-60	0-60	0-60	0-60

1.*The light outlet of the laser head is side outlet. See the mechanical dimension drawing for details

2.Customized internal beam expansion function to meet the requirements of small divergence angle (less than 2mrad)

