

# 1064nm Nd:YAG q-switched picosecond laser MC Microchip laser system



## DESCRIPTION

1064nm laser is one of the most common laser among ULaser's products of solid state laser. Unlike other lasers, 1064nm laser beam is directly emitted from the Nd:YAG crystal. Q-switched crystal helps our laser to emit picosecond output light beam. Either the one with single longitudinal mode or the one with fundamental mode can be chosen in ULaser.

ULaser provides absolute high quality 1064 nm laser. Our 1064nm laser contains high average power, up to 100mW. And it has high pulse repetition frequency, up to 50kHz. At the same time, our 1064nm laser has smaller size and lower power consumption by microchip laser technology.

Our 1064nm laser can be used in most military, civil and scientific research fields. In industry, it can be used in micromachining. In cosmetology, it can be used in picosecond laser tattoo removal machine. Besides, it can also be used in laser ultrasound, laser induced breakdown spectroscopy, etc.

## FEATURES

- Pulse width up to 550ps
- Pulse energy up to 120μJ
- High polarization direction stability
- Maximum repetition rate up to 10kHz
- Beam mode is TEM<sub>00</sub>
- Fully sealed design, high reliability

## APPLICATIONS

- Seed source
- Micromachining
- Biomedical science
- Laser ultrasonic inspection
- Laser ionization mass spectrometry
- Optical parametric oscillating pump source

## OUTLINE SIZE(mm)

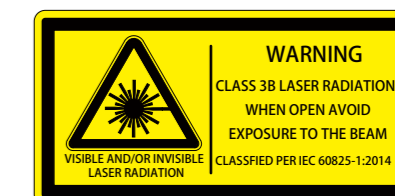
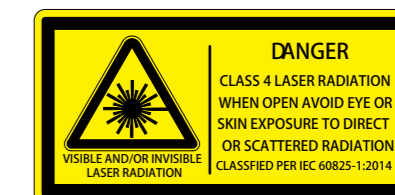
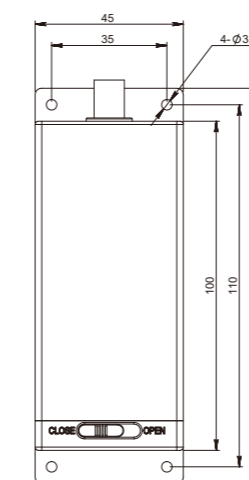
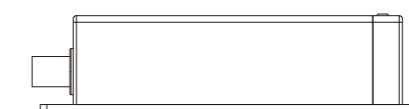
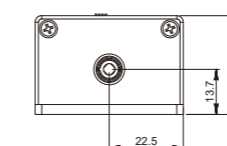
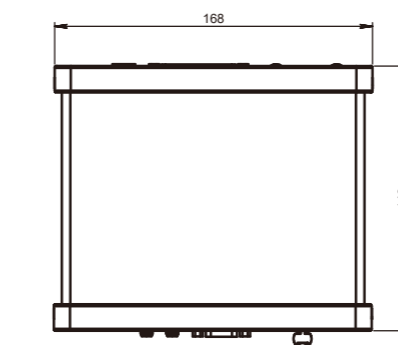
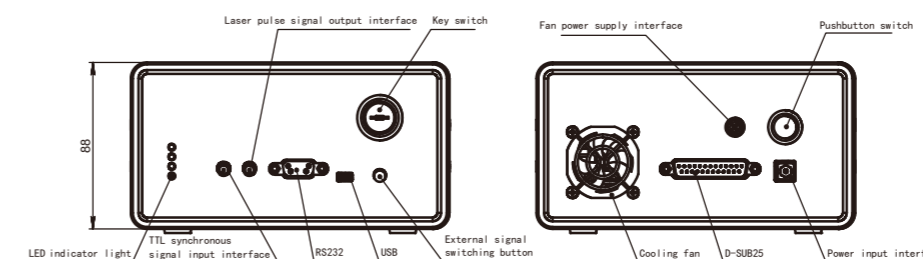

## PARAMETERS

Model	UL1064-1kHz-100μJ-MC011	UL1064-5kHz-60μJ-MC012	UL1064-10kHz-30μJ-MC013	
Optical parameter	Wavelength (nm)	1064	1064	1064
	Repetition frequency (kHz)	1	5	10
	Average power (mW)	100	300	300
	Output energy (μJ)	100	60	30
	Pulse width (ps)	750	750	750
	Power stability (8h)	±3%	±3%	±3%
	Beam mode	TEM <sub>00</sub>	TEM <sub>00</sub>	TEM <sub>00</sub>
	Full-angle divergence angle Typ. (Mrad) level@1/e <sup>2</sup>	8	12	12
	Full-angle divergence angle Typ. (Mrad) Vertical@1/e <sup>2</sup>	8	12	12
	Polarization characteristics	> 100:1	> 100:1	> 100:1
System parameters	Power input	100-240 VAC,50/60Hz	100-240 VAC,50/60Hz	100-240 VAC,50/60Hz
	Control interface	RS232, USB	RS232, USB	RS232, USB
	System power consumption (W)	≤25	≤20	≤30
	Power supply size (W × H × L, mm)	168×88×140	168×88×140	168×88×140
	Laser head size (W × H × L, mm)	45×30×120	45×30×120	45×30×120
	Working temperature (°C)	15-35	15-35	15-35
Storage temperature (°C)	0-60	0-60	0-60	

1.\*The light outlet of the laser head is side outlet. See the mechanical dimension drawing for details

2.Customized internal beam expansion function to meet the requirements of small divergence angle (less than 2mrad)

